

MaxxECU

Be a tuning mastermind. Like us.

GEN2

**MaxxECU GEN2 TRACK
quickstart guide & wiring**

Online help!
maxxecu.com/support

(2026-06-19 - REV2 harness)

maxxecu.com/support

Wirings | Documentation | Guidance | Support



MaxxECU GEN2 TRACK - Compliance, Warranty & Safety

MaxxECU GEN2 TRACK is covered by a 36-month warranty against manufacturing defects within the EU/EEA, provided that installation has been carried out professionally by a qualified installer. The product is intended for motorsport use, not for public roads, and use is at the customer's own risk with limited liability for consequential damages.

- **Warranty:** 36 months warranty against manufacturing defects. Requires proof of purchase from an authorized dealer and professional installation.
- **Safety:** Requires professional installation with proper engine grounding and disconnection of outputs during firmware updates, etc.
- **Limitation of liability:** The product is exclusively for competition vehicles (not for public roads), and all modifications are carried out at the customer's own risk.
- **Compliance:** CE marked according to EU directives (EMC, radio, RoHS) and must be disposed of as electronic waste (WEEE).
- **Do not make any changes to the ECU hardware unless approved by us. Doing so may void CE/FCC compliance.**

Manufacturer & product

Maxxtuning AB (MaxxECU), Gästgivaregatan 17, 576 96 Vrigstad, Sweden. Organisation number: 556740-1319.
Product: MaxxECU GEN2 TRACK - Engine Management System (ECU), Product ID 2492. Serial number marked on the unit.

Warranty terms and warranty limitations

MaxxECU products are warranted against defects in material or workmanship for 36 months from the date of purchase for customers within the EU/EEA. Proof of purchase from an authorised dealer is required. Defective units will be repaired or replaced if returned with valid proof of purchase.

To the extent permitted by law, the foregoing is exclusive and replaces all other warranties or representations, whether express or implied, including any implied warranty of merchantability or fitness.

Warranty scope and limitations (Warranty Limitations)

The commercial product warranty covers only original manufacturing and material defects. The warranty does NOT cover faults, damage or consequential damage to the product or the vehicle caused by:

- Incorrect, deficient or non-professional installation.
- Failure to follow the accompanying technical installation instructions.
- Incorrect configuration, programming or electrical overload at the time of installation.
- For any warranty claim, MaxxECU reserves the right to request a copy of the installation receipt, a certificate/documentation from a professional party demonstrating that the installation was carried out correctly in accordance with our instructions.
- MaxxECU or its associates shall never be liable for special or consequential damages.
- This warranty is provided in addition to, and does not affect, the customer's mandatory statutory rights as a consumer depending on the country of purchase, for example, a 3-year right of complaint in Sweden and a minimum 2-year EU guarantee.

Installation, safety and requirement for professional competence

This electronic control unit (ECU) is an advanced vehicle component that requires specific automotive knowledge of the vehicle's electrical system in order to be installed safely and correctly.

The product should preferably be installed by a certified automotive technician or a professional workshop, or by someone with equivalent knowledge.

The following safety aspects must be met for the warranty to apply:

- Incorrect ignition or fuel configuration can damage the engine when the ECU is powered up.
- Always disconnect all outputs when updating firmware; updates are optional, free, advisable but not mandatory. Never update just before a competition, and MaxxECU accepts no liability for updates or software bugs.
- The ECU's engine ground must always connect to the cylinder head; engine and battery negative must always be grounded to the chassis/cylinder head.
- Disconnect the battery before electrical work or welding; never disconnect it while the engine is running.
- Keep fuel components and cables away from heat; ensure there are no fuel leaks and no uninsulated cables.
- Avoid open flames, sparks or electrical devices near flammable substances, and follow proper workshop safety procedures.

Legal disclaimer

All performance modifications and installations are at the customer's own risk. MaxxECU or its associates disclaim any liability, whether implied or otherwise, for mechanical, electrical or other failure when using any of our aftermarket products. As MaxxECU products are freely programmable, MaxxECU holds no responsibility for any settings, mapping or calibrations created or applied by the customer or any third party. The products are sold for motorsport use only and may be illegal for road use in many countries, states and provinces. They are intended solely for racing vehicles and should never be used on public roads. By purchasing any MaxxECU aftermarket product, the customer assumes full responsibility for all use and/or misuse of the product, and agrees that MaxxECU holds no responsibility for any consequences, whether legal or otherwise, of such use and/or misuse. Nothing in this disclaimer excludes or limits liability for death or personal injury caused by negligence, for fraud, or any liability that cannot be excluded under mandatory law, nor any statutory rights the customer has as a consumer. These terms are governed by Swedish law.

Waste disposal (WEEE)

This product must not be disposed of with household waste. Return it to your dealer or to a collection point for electrical waste (Directive 2012/19/EU).

All MaxxECU products are for motorsport use only. They are not intended for use on the roads.

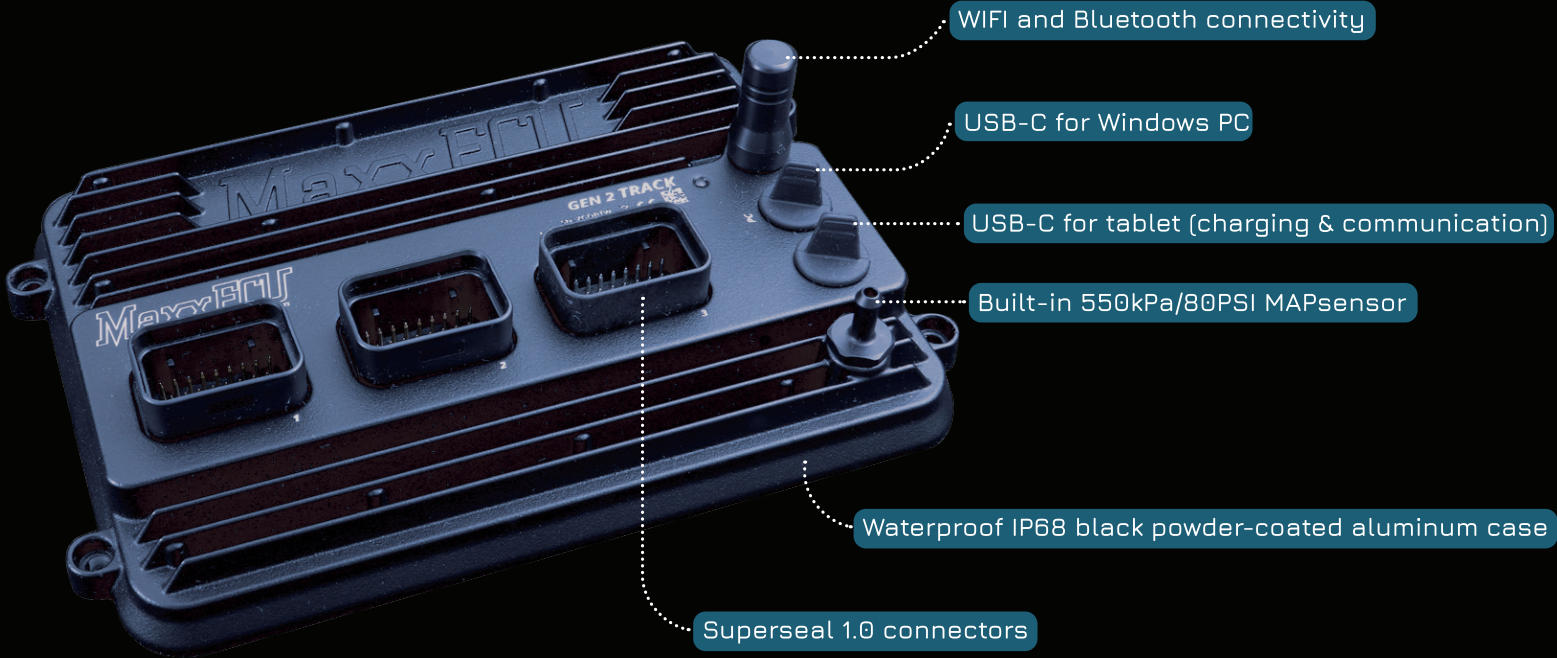

Software installation

1. Download MTune PC-software from maxxecu.com/mtune
2. Run the downloaded installer and follow the on-screen instructions.

Help system

MaxxECU documentation is always available from maxxecu.com/support and is also integrated into MTune PC software.



Access to integrated help is available within MTune PC software by pressing the help button shown above, or by pressing the F1 key.

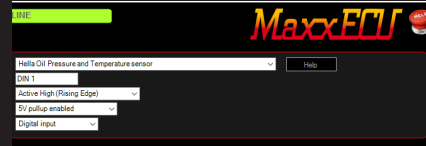

Integrated help is also available within MTune PC software after each input/output to get fast help.

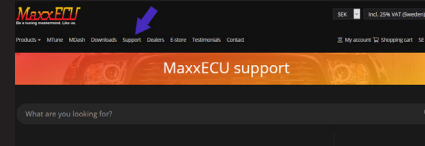

Support page and documentation available on maxxecu.com/support.

ECU installation

GEN2 units are waterproof and can be mounted in the engine bay, provided they are kept away from excessive heat sources. However, for maximum reliability and protection from vibration, moisture, and temperature extremes, installation inside the vehicle cabin is recommended.

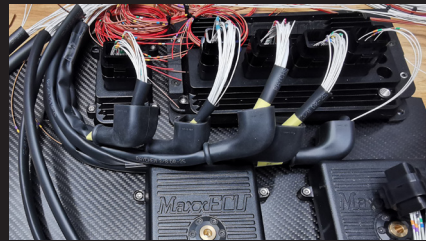

Wiring - A proper wiring job is important to get a reliable vehicle.



Example of a finished engine harness.



Use a firewall bushing to prevent damage to the cables.



Use shrink tubing with adhesive when splicing cables.

Engine ground - **Very important!**

- Battery negative (-) must connect to the chassis or cylinder head.
- Engine must be grounded to the chassis.
- ECU engine ground must connect to the cylinder head.



Inputs

AIN (Analog Input)

- Accepts 0–5 V analog or digital signals, max 24 V.
- Digital threshold: 3 V. Selectable 2.5 k Ω 5 V pull-up.
- Analog update rate: 2 kHz. Input resistance: 200 k Ω .
- Switches/buttons and other slow signals in digital mode.

Note: Ethanol sensors, BSD, SENT, etc. are not supported here - use PULSE inputs instead.

Digital/VR (PULSE)

- Accepts digital or VR signals, max 200 V, up to 30 kHz.
- Selectable internal ground or floating (set in MTune).
- Input resistance: 62 k Ω .

Note: Floating mode is only for piggyback use when sharing trigger/ABS sensors.

RPM requirements:

- Trigger sensor: wired to any PULSE input
- Home/CAM sensor: required for sequential operation, and in some trigger systems also for RPM detection.

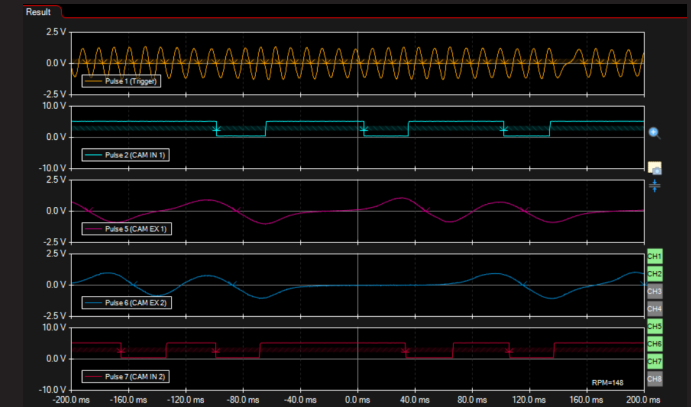

Built-in trigger oscilloscope for diagnosing signals. Screenshot shows a crank VR sensor on PULSE1 (yellow), a VWTi cam signal (blue), and digital VWTi position signals (green, purple, red).
[Diagnostics --> Trigger oscilloscope](#)

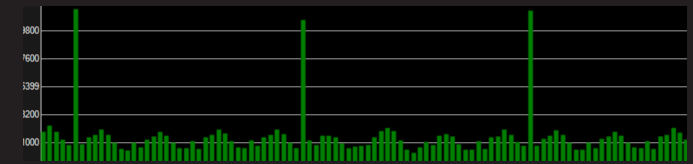

Using the built-in trigger logger, connected signals can be examined and sent to us for implementations of new trigger types.
[Diagnostics --> Trigger logger](#)



Wiring or trigger problem? --> Contact YOUR local MaxxECU dealer, or go to maxxecu.com/support

Outputs

GPO (Low)

- Ground-switching (sinking) output for general loads.
- Connect load between output and +12 V (switched) source.
- Active = ground, off = floating.
- Max 3 A continuous. Protected against overload, short circuit. Flyback protection 30V.

12 V GPO

- 12 V sourcing output for general loads.
- Active = 12 V, off = floating.
- Max 5 A continuous. Protected against overload, short circuit. Flyback protection 30V.

Note: For >10 A combined load, use both ECU Supply 1 & 2. Total max 30 A to prevent wiring/connector overheating.

Injector (Peak/Hold)

- Ground-switching output for injectors (also usable for general loads).
- Connect load between output and +12 V (switched) source.
- Active = ground, off = floating.
- Max 10 A peak / 5 A continuous. Selectable peak/hold currents.
- Flyback protection 30 V with automatic regulation for fast, precise injector control.

Ignition

- 5 V or 12 V push-pull, or ground-switching output (set in MTune).
- Drives external ignition modules/smart coils or general loads.
- Push-pull: 5/12 V when active, ground when off. 100 mA limit.
- Ground-switch: ground when active, floating when off. 1 A limit.
- Flyback protection 30V.

H-Bridge

- 12 V push-pull (half-bridge) output for motors or loads.
- Active = 12 V, off = ground.
- For bidirectional motors (e.g., throttles): connect the load between two H-bridge outputs.
- For general loads: connect the load between one H-bridge output and ground.
- Overload and short-circuit protected. PWM current-limiting.
- Max 7.5A-15 A (selectable), 10A continuous.



Wiring problem? --> Contact YOUR local MaxxECU dealer, or go to maxxecu.com/support

Engine start

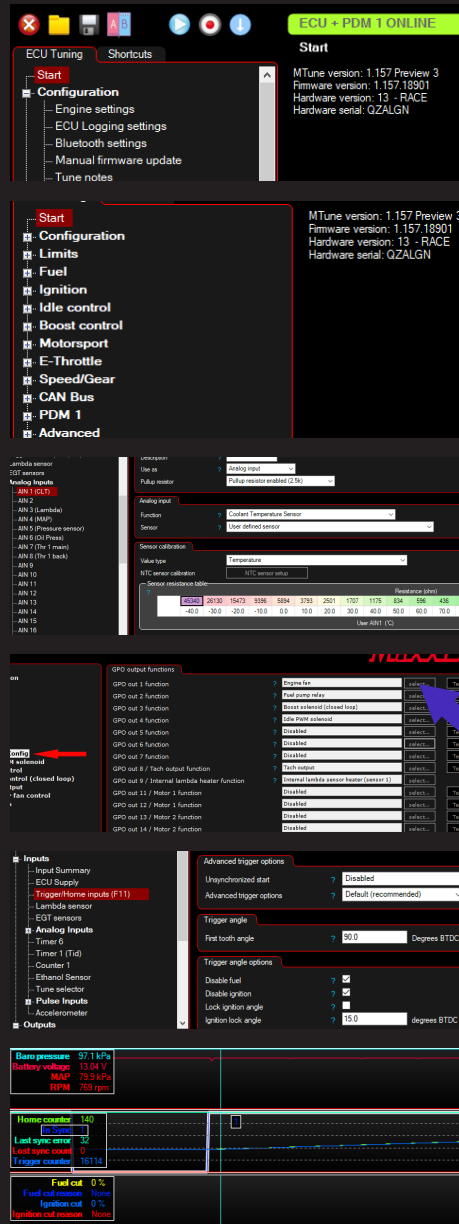

After installing MTune, connect the included USB cable and power up the ECU. To get started quickly, load a suitable base-tune directly from within MTune (no download needed) using the yellow "Open" icon and follow the on-screen instructions.

In MTune, go through the tabs and make a basic engine setup. Key settings include:

- Cylinders, firing order, engine volume. [Configuration --> Engine settings](#)
 - Ignition coil dwell and system type- [Ignition --> Ignition settings](#)
 - Injector type and fuel type. [Fuel --> Fuel Inj General](#)
 - Trigger system and correct decoder. [Inputs --> Trigger / Home inputs](#)
- Tip: Use the built-in oscilloscope, trigger logger, and other tools to verify trigger setup.

Throttle / CLT / IAT Calibration

Regular throttle: Calibrate TPS at 0% and 100% using the 2-point buttons in the analog input settings.
E-throttle: TPS shows pedal position; calibrate sensors in E-throttle settings.
CLT & IAT: Select correct sensors and verify values in RealTime Data.

Please note that TPS value is pedal position when using E-Throttle.

Configure all outputs according to your wiring. [Outputs --> Output config](#)
Use [Diagnostics --> Output test](#), to test configured injectors and coils.

To crank without starting, disable fuel/ignition under [Inputs --> Trigger/HOME inputs](#), [Trigger angle options](#). Remember to re-enable before starting the engine.

Start cranking, check trigger polarity, and adjust timing with a timing lamp.

[Diagnostics --> Trigger oscilloscope](#) - View live trigger inputs.
[Diagnostics --> Trigger logger](#) - View timing between trigger events.
[Inputs --> Trigger, Trigger angle options](#) - Use lock ignition advance to sync timing.

When all inputs/outputs are configured and engine settings, trigger systems and ignition are synced, it is time to try to start the engine.

MaxxECU

All AIN have selectable pullups.

Example wiring. All AIN functions are assigned in MTune.

Digital input switch wiring examples

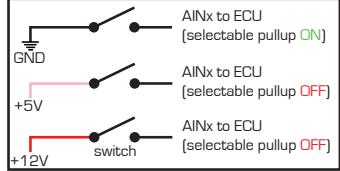

Sensor or Shield GND must **NEVER** be connected to chassis OR engine!

Example wiring for trigger signals. All Pulse Input functions are assigned in MTune. Any Pulse inputs may be used for trigger signals. All Pulse inputs support both VR and digital signals.

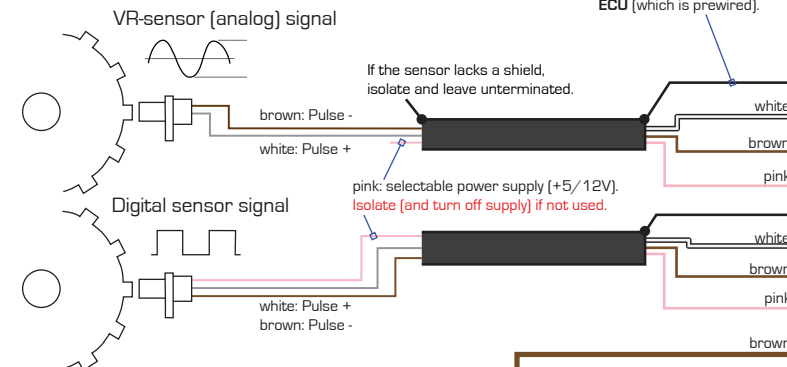
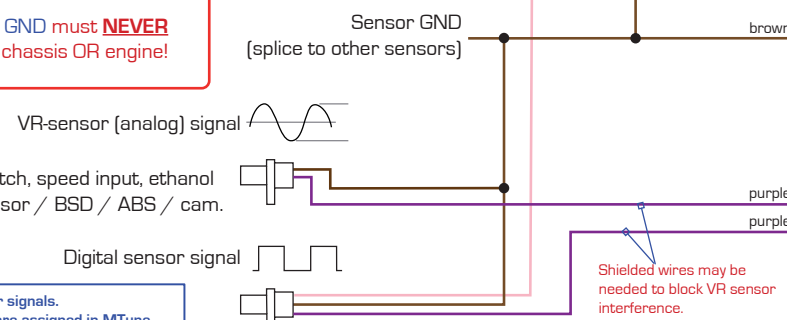
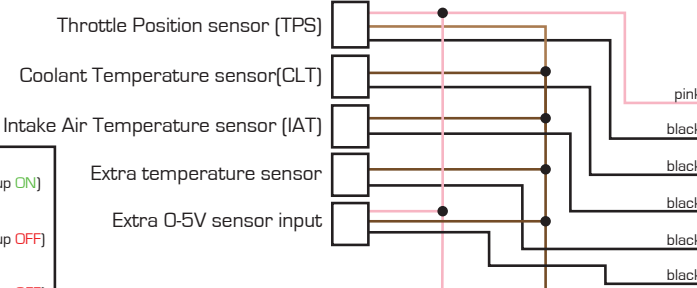

Digital supply selectable 5V or 12V
Always verify sensor specifications with the manufacturer before connection.

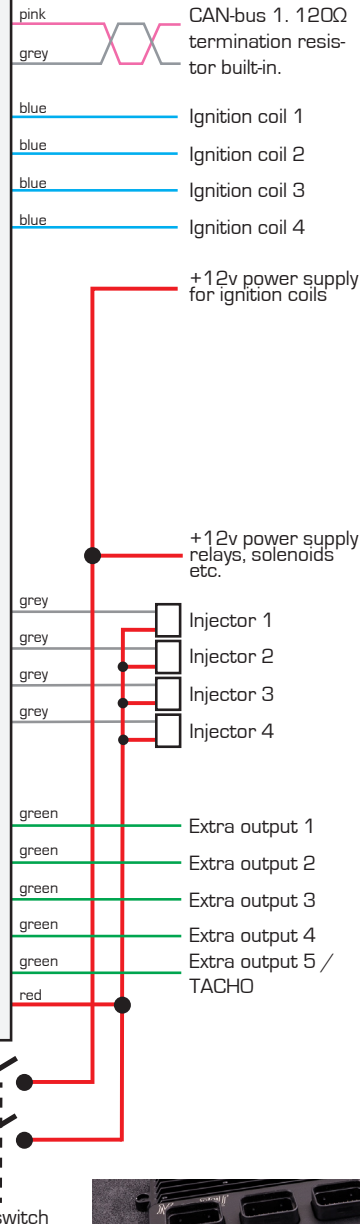
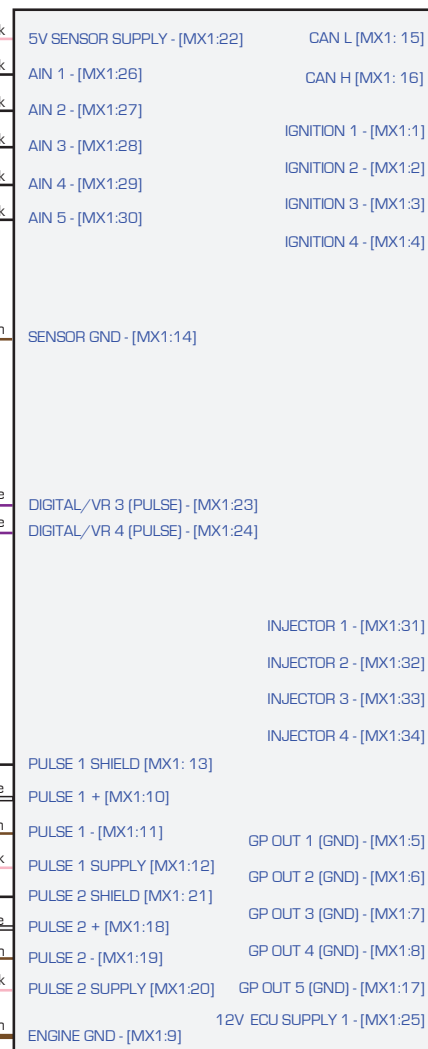

Ignition output examples (5V/ 12V or ground).

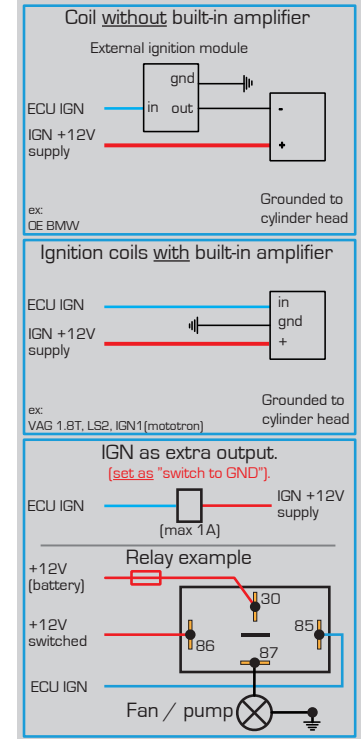

INJ and GP ground output examples.

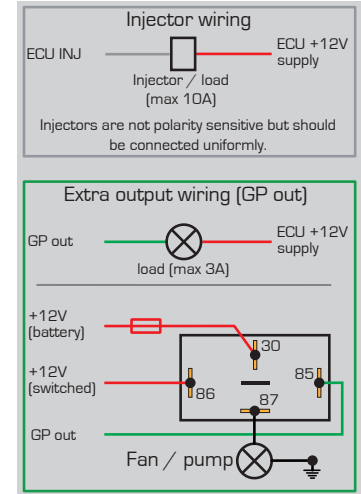

Available connector kit
Superseal 1.0, key MX1
Product ID: [2416](#)

MaxxECU GEN2 TRACK/RACE (MX1)
2026-06-11
maxxecu.com/support

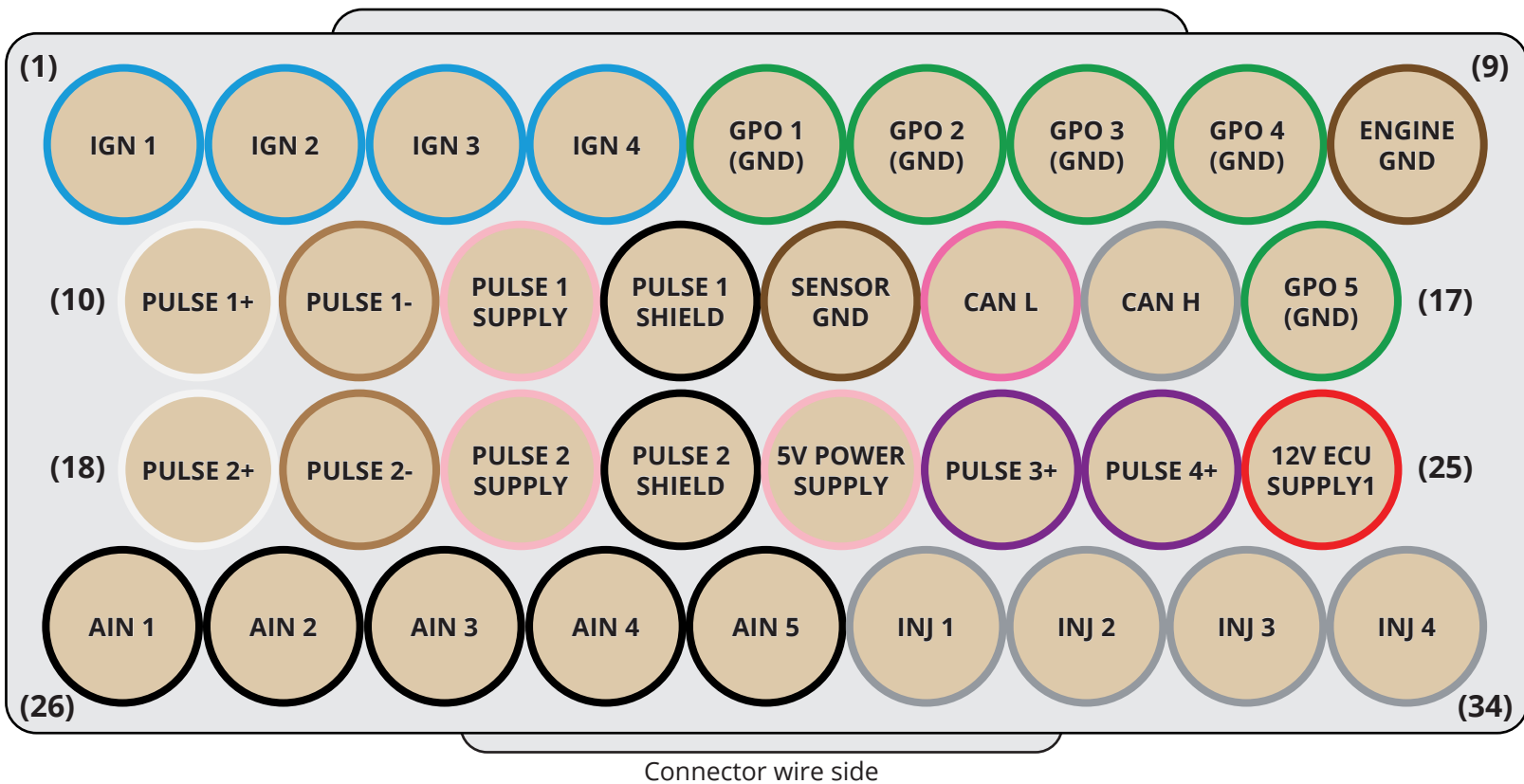

Connector wire side

MX1 keying



ECU side

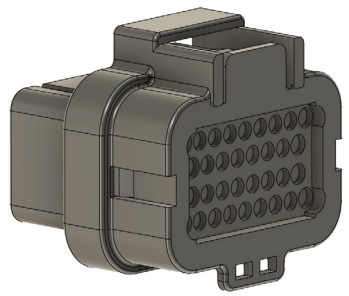

Wire side

Pin	Function	Note
1	IGNITION 1	
2	IGNITION 2	
3	IGNITION 3	
4	IGNITION 4	
5	GP OUT 1 (GND)	
6	GP OUT 2 (GND)	
7	GP OUT 3 (GND)	
8	GP OUT 4 (GND)	
9	ENGINE GND	
10	DIGITAL/VR 1 (PULSE) SIGNAL +	
11	DIGITAL/VR 1 (PULSE) SIGNAL -	
12	DIGITAL/VR 1 (PULSE) POWER SUPPLY	
13	DIGITAL/VR 1 (PULSE) SHIELD	
14	SENSOR GND	
15	CAN L	
16	CAN H	
17	GP OUT 5 / TACHO (GND)	

Pin	Function	Note
18	DIGITAL/VR 2 (PULSE) SIGNAL +	
19	DIGITAL/VR 2 (PULSE) SIGNAL -	
20	DIGITAL/VR 2 (PULSE) POWER SUPPLY	
21	DIGITAL/VR 2 (PULSE) SHIELD	
22	5V POWER SUPPLY	
23	DIGITAL/VR 3 (PULSE) SIGNAL +	
24	DIGITAL/VR 4 (PULSE) SIGNAL +	
25	12V ECU SUPPLY 1	
26	AIN 1	
27	AIN 2	
28	AIN 3	
29	AIN 4	
30	AIN 5	
31	INJECTOR 1	
32	INJECTOR 2	
33	INJECTOR 3	
34	INJECTOR 4	

Sensor or Shield GND must **NEVER** be connected to chassis OR engine!

MaxxECU

Sensor GND (from connector 1)
5V SUPPLY (from connector 1)

Extra temperature / 0-5V sensor inputs
- All AIN have selectable pullups.
- Functions are assigned in MTune.

Connector wire-side view (terminal insertion side)

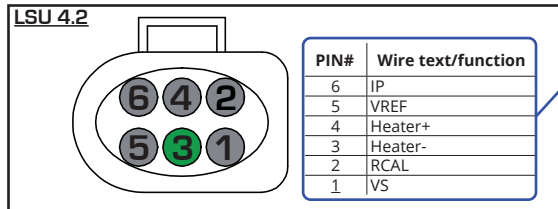
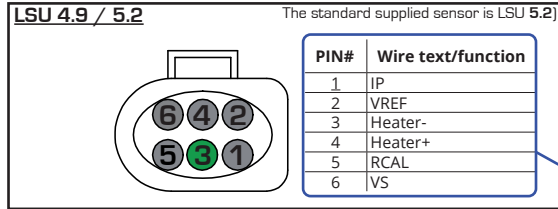

Use only recommended sensors:
LSU 5.2: Bosch 0258 037 010 / 0258 037 022
LSU 4.9: Bosch 0281 004 191 / 0258 017 025
LSU 4.2: Bosch 0258 007 057

Knock sensor #1



Knock sensor #2



Use only recommended sensors:
Bosch 0261 231 046
(Knock sensor(s) are not polarity sensitive)

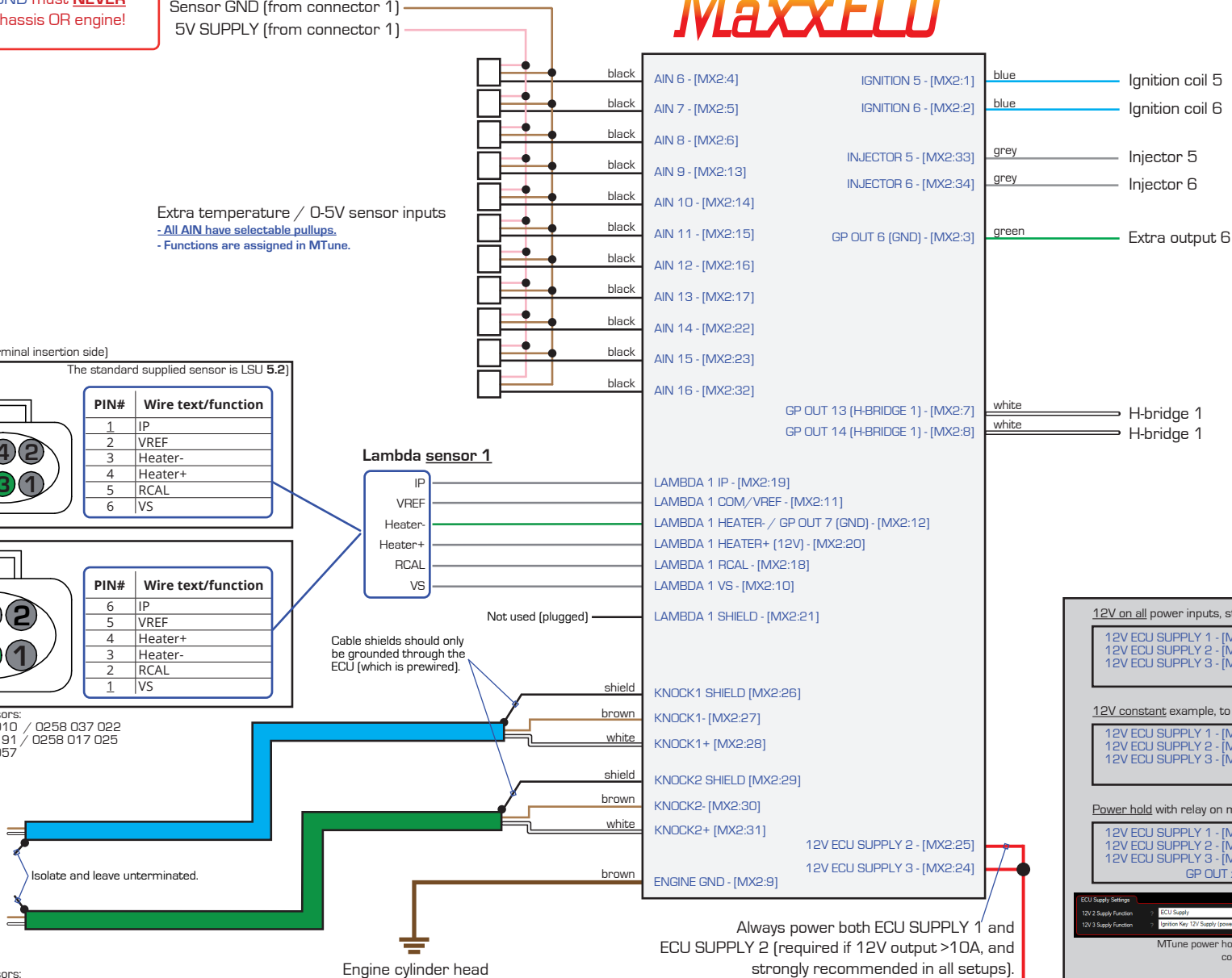

Always power both ECU SUPPLY 1 and ECU SUPPLY 2 (required if 12V output >10A, and strongly recommended in all setups).

Use the same power source as connector 1 (MX1).

Refer to the wiring diagram for GEN2 connector 1 (MX1) for Ignition, Injector, and GP output connections.

H-bridge output examples

General purpose load



Bidirectional motor control

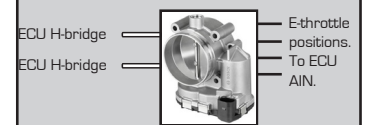

Power wiring examples

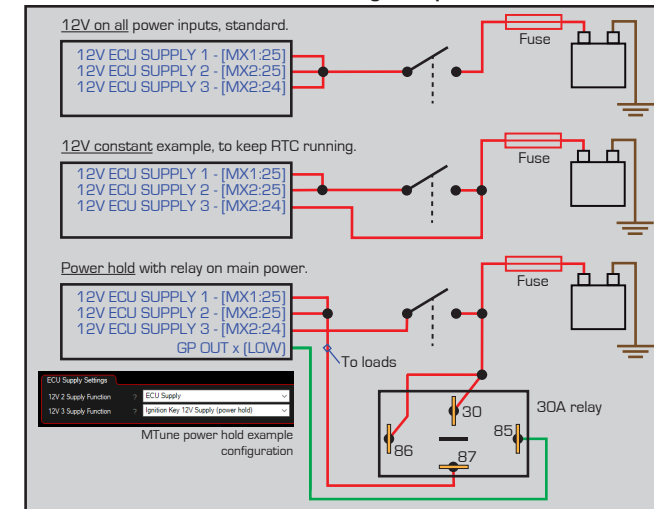

MaxxECU GEN2 RACE/TRACK (MX2)
REV2 harness 2026-06-19
maxxecu.com/support

Available connector kit
Supersal 1.0, key MX2
Product ID: 2417

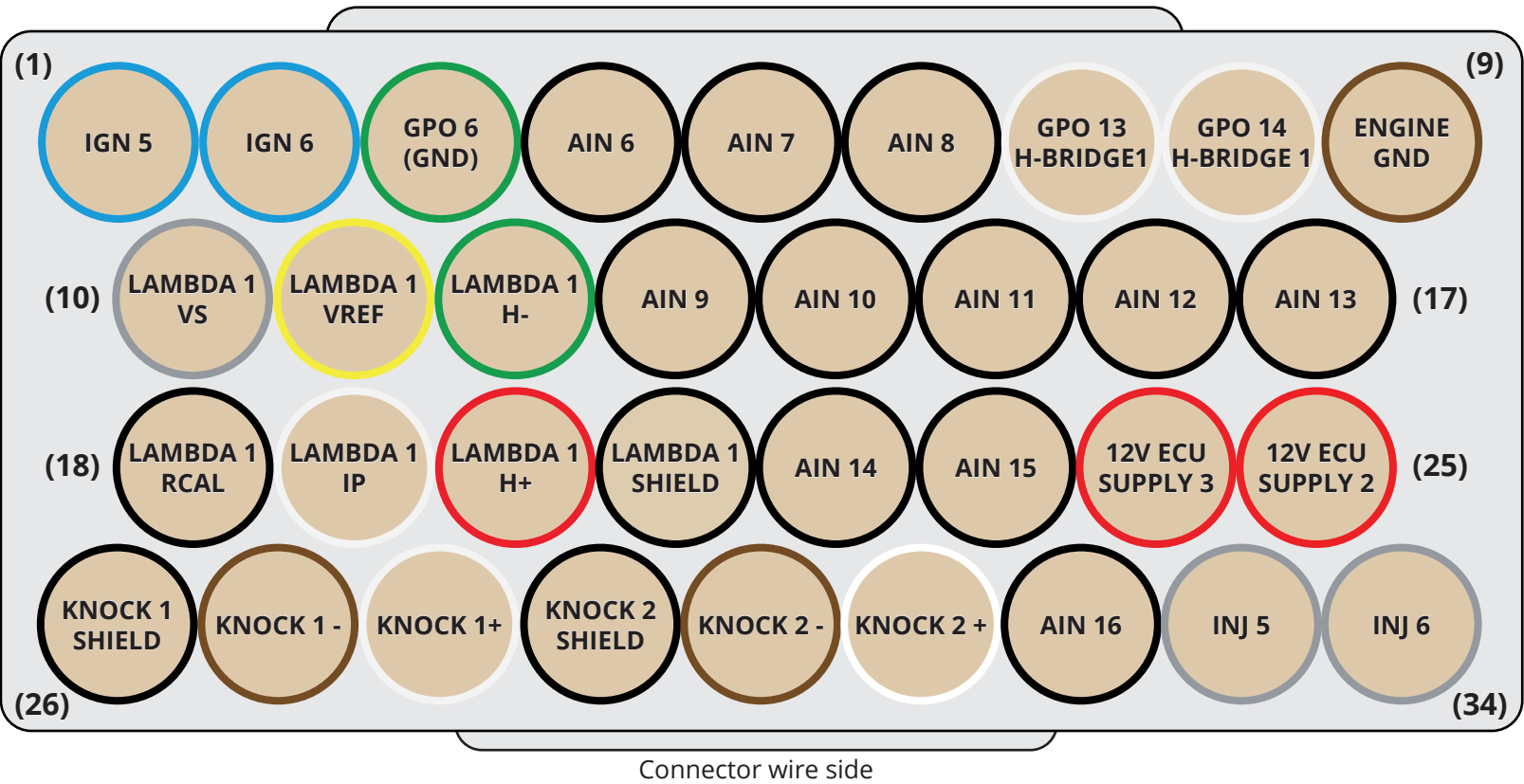

MX2 keying

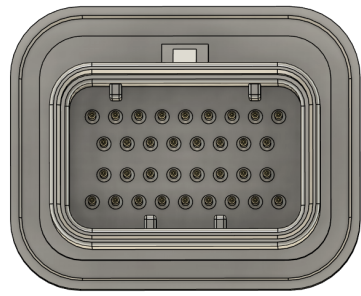

ECU side

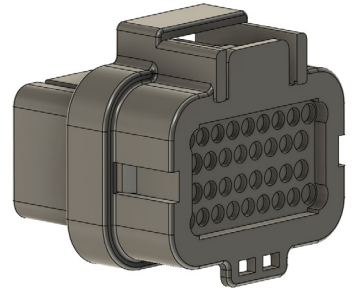

Wire side

Pin	Function	Note
1	IGNITION 5	
2	IGNITION 6	
3	GP OUT 6 (GND)	
4	AIN 6	
5	AIN 7	
6	AIN 8	
7	GP OUT 13 (H-BRIDGE 1)	
8	GP OUT 14 (H-BRIDGE 1)	
9	ENGINE GND	
10	LAMBDA 1 VS	
11	LAMBDA 1 COM/VREF	
12	LAMBDA 1 HEATER- / GP OUT 7 (GND)	
13	AIN 9	
14	AIN 10	
15	AIN 11	
16	AIN 12	
17	AIN 13	

Pin	Function	Note
18	LAMBDA 1 RCAL	
19	LAMBDA 1 IP	
20	LAMBDA 1 HEATER+ (12V)	
21	LAMBDA 1 SHIELD	Not used in REV2 harness
22	AIN 14	
23	AIN 15	
24	12V ECU SUPPLY 3	
25	12V ECU SUPPLY 2	
26	KNOCK 1 SHIELD	
27	KNOCK 1-	
28	KNOCK 1+	
29	KNOCK 2 SHIELD	
30	KNOCK 2-	
31	KNOCK 2+	
32	AIN 16	
33	INJECTOR 5	
34	INJECTOR 6	

Available connector kit
 Superseal 1.0, key MX2
 Product ID: [2417](#)

Sensor or Shield GND must **NEVER** be connected to chassis OR engine!

Example wiring for trigger signals.
All Pulse Input functions are assigned in MTune.
Any Pulse inputs may be used for trigger signals.
All Pulse inputs support both VR and digital signals.

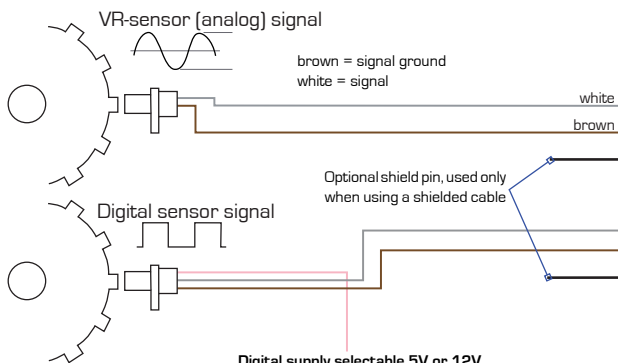

Digital supply selectable 5V or 12V
Always verify sensor specifications with the manufacturer before connection. For powered digital sensors, use a switched 12V source or the 5V sensor supply from connector 1 (MX1), according to the sensor's requirements.

Connector wire-side view (terminal insertion side)

LSU 4.9 / 5.2 The standard supplied sensor is LSU 5.2

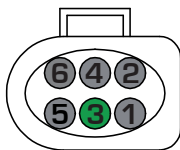

PIN#	Wire text/function
1	IP
2	VREF
3	Heater-
4	Heater+
5	RCAL
6	VS

LSU 4.2

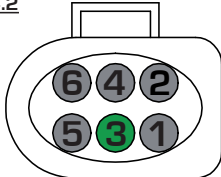

PIN#	Wire text/function
6	IP
5	VREF
4	Heater+
3	Heater-
2	RCAL
1	VS

Use only recommended sensors:
LSU 5.2: Bosch 0258 037 010 / 0258 037 022
LSU 4.9: Bosch 0281 004 191 / 0258 017 025
LSU 4.2: Bosch 0258 007 057

Lambda sensor 2

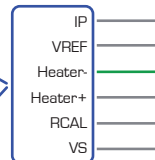

Not used (plugged)

MaxxECU

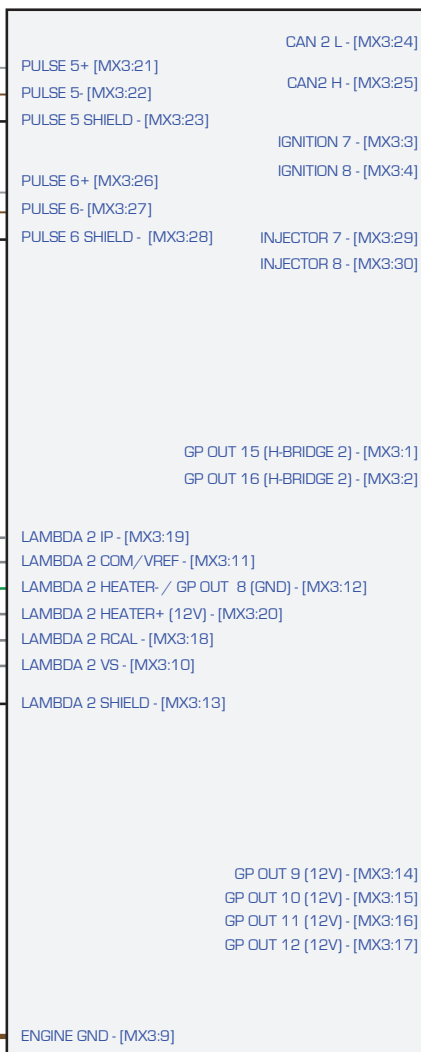

CAN 2 L - [MX3:24] white
CAN 2 H - [MX3:25] grey
Selectable 120Ω termination resistor built-in.

IGNITION 7 - [MX3:3] blue
IGNITION 8 - [MX3:4] blue
Ignition coil 7
Ignition coil 8

INJECTOR 7 - [MX3:29] grey
INJECTOR 8 - [MX3:30] grey
Injector 7
Injector 8

GP OUT 15 (H-BRIDGE 2) - [MX3:1] white
GP OUT 16 (H-BRIDGE 2) - [MX3:2] white
H-bridge 2
H-bridge 2

GP OUT 9 (12V) - [MX3:14] white
GP OUT 10 (12V) - [MX3:15] white
GP OUT 11 (12V) - [MX3:16] white
GP OUT 12 (12V) - [MX3:17] white
Extra output 9
Extra output 10
Extra output 11
Extra output 12

ENGINE GND - [MX3:9] brown

Engine cylinder head

Refer to the wiring diagram for GEN2 connector 1 (MX1) for Ignition and Injector connections.

Refer to the wiring diagram for GEN2 connector 2 (MX2) for H-bridge connections.

GP 12V output examples.

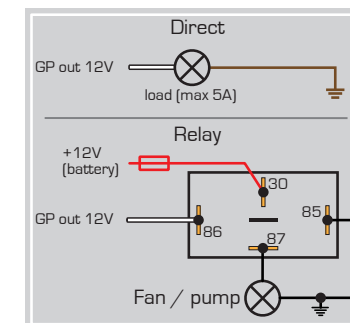

12V1 and 12V2 power inputs required if 12V TOTAL output exceeds 10A. See GEN2 connector 2 (MX2) wiring diagram.

Available connector kit
Superseal 1.0, key TRACK MX3
Product ID: [2525](#)



MaxxECU GEN2 TRACK (MX3)
REV2 2026-06-19
maxxecu.com/support

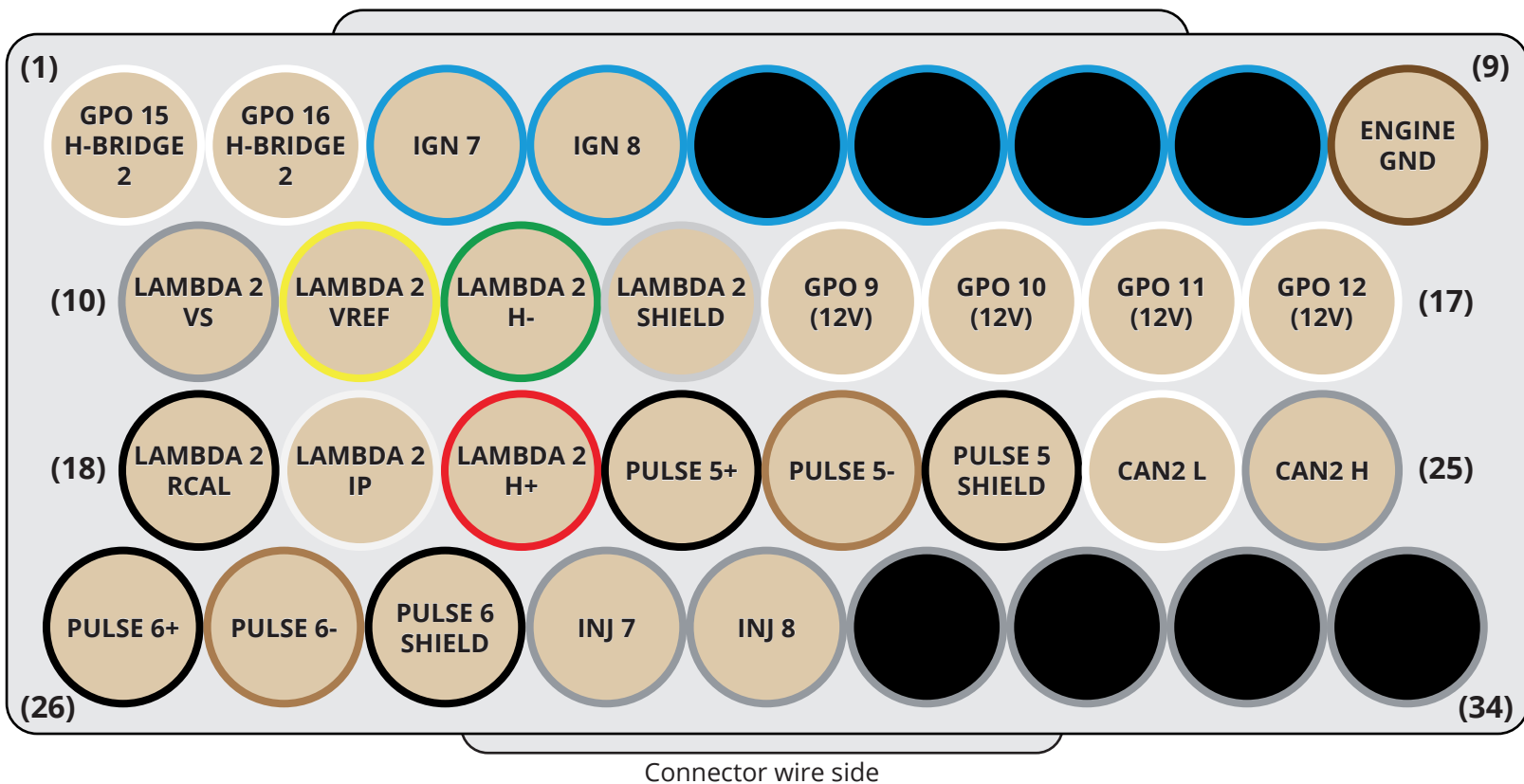

Connector wire side

MX3 keying

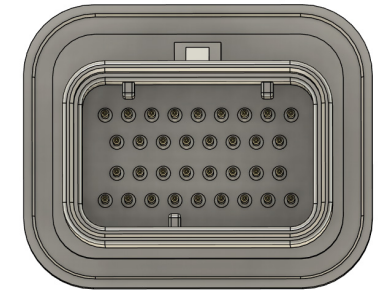

ECU side

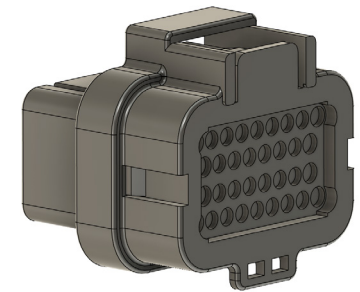

Wire side

Pin	Function	Note	Pin	Function	Note
1	GP OUT 15 (H-BRIDGE 2)		18	LAMBDA SENSOR 2 RCAL	
2	GP OUT 16 (H-BRIDGE 2)		19	LAMBDA SENSOR 2 IP	
3	IGNITION 7		20	12V LAMBDA SENSOR 2 (H+)	
4	IGNITION 8		21	PULSE 5+	
5	NOT USED		22	PULSE 5-	
6	NOT USED		23	PULSE 5 SHIELD	
7	NOT USED		24	CAN2 L	
8	NOT USED		25	CAN2 H	
9	ENGINE GND		26	PULSE 6+	
10	LAMBDA SENSOR 2 VS		27	PULSE 6-	
11	LAMBDA SENSOR 2 VREF		28	PULSE 6 SHIELD	
12	GP OUT 8 (GND) / LAMBDA SENSOR 2 H-		29	INJECTOR 7	
13	LAMBDA SENSOR 2 SHIELD		30	INJECTOR 8	
14	GP OUT 9 (12V)		31	NOT USED	
15	GP OUT 10 (12V)		32	NOT USED	
16	GP OUT 11 (12V)		33	NOT USED	
17	GP OUT 12 (12V)		34	NOT USED	



MaxxECU GEN2 TRACK

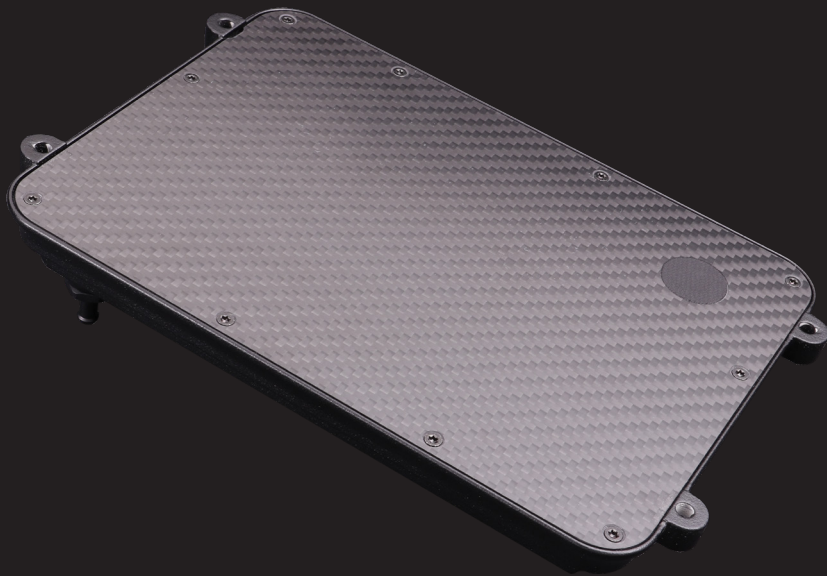

Need help? --> Contact YOUR local MaxxECU dealer, or go to maxxecu.com/support

Thank you for using MaxxECU!
"You as a customer is our most valued asset"

MaxxECU
Be a tuning mastermind. Like us.



GEN2

www.maxxecu.com